



Certificate DIN ISO 9001: 1994

UP50H / UP100H

Instruction manual

Ultrasonic processors for
Laboratories

Imprint

Instruction manual UP50H and UP100H ultrasonic processors

Ultrasonic processors for use in the laboratory.

Purpose and use

This instruction manual shows you the construction and operation of the UP50H and UP100H ultrasonic processors. The structure, areas of use and handling of both ultrasonic processors are practically the same, the respective power outputs differ.

Please ensure that you read the safety information particularly carefully and comply with it at all times.

Always keep the manual near the areas in which the UP50H and UP100H ultrasonic processors are used. The instruction manual should always be to hand, to help you to solve any questions that may arise.

All rights reserved

This instruction manual must not be completely or partly reproduced or duplicated in any form or by any means without the prior written consent of Dr. Hielscher GmbH.

The manual has been prepared with all due care, nevertheless errors and omissions cannot be fully precluded.

Dr. Hielscher GmbH reserves the right to make changes to the technical data and specifications during the course of further development of the product, without giving prior notice.

The company and product names mentioned in this manual can be registered trademarks. They are the property of their respective holder and are herewith acknowledged.

We do not accept any liability for damages, which result from failure to observe the information in this manual.

Address

Dr. Hielscher GmbH
Warthestraße 21
14513 Teltow

Telephone	+49 (0) 33 28 / 437 3
Fax	+49 (0) 33 28 / 437 444
eMail	service@hielscher.com

List of Contents

1	Product Description	4	
	1.1	Designations used in this manual	4
	1.2	Overall view	4
	1.3	Areas of use	5
	1.4	Equipment and accessories (extent of delivery)	6
	1.5	Designation.....	7
	1.6	Technical data	7
	1.7	Available accessories	8
2	Safety	11	
	2.1	Symbols used	11
	2.2	Use as prescribed.....	12
	2.3	Safety information.....	12
3	Structure and Function	14	
	3.1	Structure.....	14
	3.2	Functional principle.....	14
	3.3	Operating and display elements.....	15
	3.4	Electrical connection.....	17
	3.5	Sonotrodes	17
4	Commissioning	18	
	4.1	Room requirements	18
	4.2	Install and dismantle the sonotrode	18
	4.3	Stand assembly	20
	4.4	Electric connection.....	21
	4.5	PC or timer connection	22
5	Operation	23	
	5.1	Manual mode – the correct hold.....	23
	5.2	Switch the ultrasonic processor on and off..	23
	5.3	Vary the working parameters	25
6	Help With Faults	27	
	6.1	Faults.....	27
	6.2	Service address and telephone number.....	28
7	Servicing and Maintenance	29	
8	Decommissioning and Transport	30	
9	Disposal	31	
10	Appendix	32	

1 Product Description

The UP50H and UP100H ultrasonic processors have been developed for use in the laboratory, the areas of use and operation of the two ultrasonic processors are the same.

The ultrasonic transducers use electric excitation to generate ultrasound, which is transferred to the liquid medium via various sonotrodes. Both ultrasonic processors are suitable for both manual mode as well as for assembly on a stand.

The difference between the UP50H and UP100H ultrasonic processors lies in their useful output power:

UP50H	50 W
UP100H	100 W

Outwardly, the two designs only differ in the various designations on the labels on their housings.

1.1 Designations used in this manual

This instruction manual applies for the two UP50H and UP100H ultrasonic processors.

The following designations are used:

Ultrasonic processor	The generic designation is used in all sections, which apply for both variants.
UP50H	All information, which only concerns the UP50H, will be denoted with this product title.
UP100H	All information, which only concerns the UP100H, will be denoted with this product title.

1.2 Overall view

The ultrasonic processor is supplied in a portable case, which also contains all accessories and the required tools.

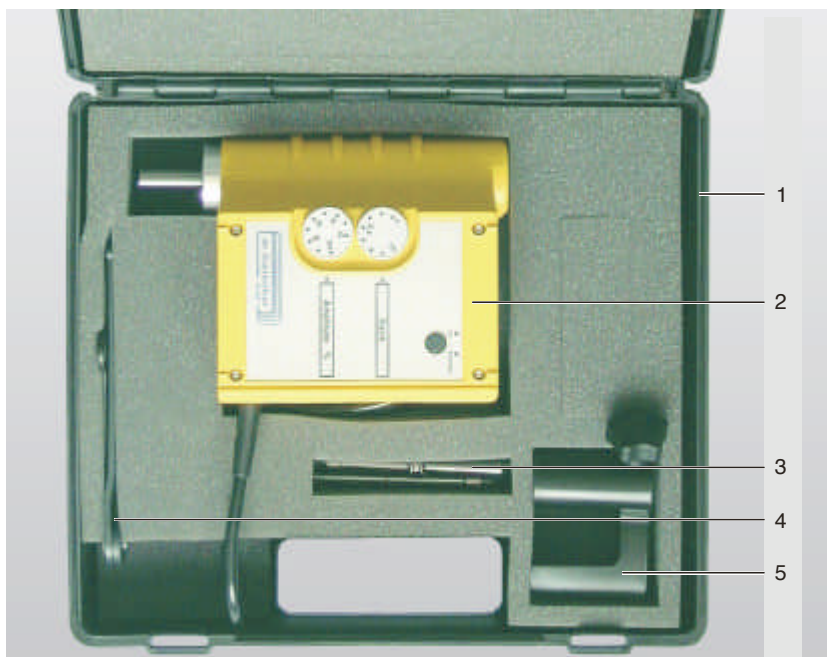

- Key**
- 1 Portable case
 - 2 Ultrasonic processor
 - 3 Sonotrode(s)
 - 4 Tool
 - 5 Stand clamp

Figure 1-1 Overall view: ultrasonic processor in portable case

1.3 Areas of use

The UP50H and UP100H ultrasonic processors have a large range of applications for use in biology, medicine, chemistry and engineering, whereby the UP50H and UP100H provide different useful output powers (see Section 1.6 “Technical data”).

Despite their high efficiency, the ultrasonic processors do not have to be artificially cooled and are suitable for continuous operation. The amplitude of the oscillatory system can be steplessly adjusted between 20% and 100%, the set value remains constant under all operating conditions. This means that even continuous operation in air is possible.

The sonotrodes are power-adjusted and can therefore be run without amplitude limitation.

You can expose temperature-sensitive samples to high intensity ultrasonic waves in pulse control mode. The pulse mode factor between non-operation and acoustic irradiation can be continuously varied between 10% and 100%.

The UP50H and UP100H ultrasonic processors are used for the following tasks:

Sonochemistry

The ultrasonic processors can be used in sonochemistry in the standard laboratory vessels. Prerequisite for this is choice of

laboratory vessels according to the media to be acoustically irradiated and the sonotrode size.

Biology, medicine and chemistry laboratories

The UP50H and UP100H ultrasonic processors can be used in laboratories, for example to carry out the following works:

- Disintegration or homogenisation of liquids
- Fine screening granular substances
- Intensive cleaning of flat substrates
- FIA in biochemistry

Engineering

- Thermoplastic deformation
- Removing protective coats

Further areas of use

Further areas of use are feasible and depend on the sonotrodes available. In case of doubt, please contact the customer service department of Dr. Hielscher GmbH. The address and telephone number are given in Section 6.2 "Service address and telephone number".

1.4 Equipment and accessories (extent of delivery)

The extent of delivery is determined by the order. In particular, the sonotrodes supplied with the ultrasonic processor depend on the planned use.

The electrical connections are specified by Dr. Hielscher GmbH before delivery, typical for the country of use according to the customer's order (see Section 1.6 "Technical data"). The electrical connections must not be changed by the user of the ultrasonic processor!

Basic equipment, standard extent of delivery

The portable case with foam inner lining contains:

- Ultrasonic processor (UP50H or UP100H, depending on the order)
- Adjustable face spanner, Size 3
- Open jawed spanner SW 9
- Instruction manual
- Accessories according to the order

Special equipment

Please note any enclosed separate documentation on the use and installation of the accessories.

1.5 Designation

Manufacturer	Dr. Hielscher GmbH
Title	UP50H / UP100H
Conformity	CE mark (for verifications, please see the "conformity declaration" given in the appendix to this instruction manual)
Year of construction	See rating plate

1.6 Technical data

Technical specification

Ultrasonic processors	UP50H / UP100H
Efficiency	> 90 %
Working frequency	30 kHz
Control range	± 1 kHz
Output control	20% ...100%, steplessly adjusted
Pulse-pulse mode factor	10% ... 100% pro second, steplessly adjusted
Test certificates	See the "conformity declaration" given in the appendix to this instruction manual

Electrical data

Connected loads	200 ... 240 V AC, 48 ... 63 Hz, alternatively (typical for country of use) 100 ...120 V AC, 48 ... 63 Hz
Fuses	UP50H / 230 V: 0.63 A UP100H / 230 V: 1 A

	UP50H / 110 V: 1 A
	UP100H / 110 V: 2 A
Useable /nominal output	UP50H: 50 W (in aqueous media 45 W)
	UP100H: 100 W (in aqueous media 90 W)
Maximum energy density	125 ... 600 W/cm ² depending on the sonotrode
Maximum amplitude	125 ... 220 μ m depending on the sonotrode

Operational safety

Protection class	I, earthed device
Degree of protection	IP 40

Permissible ambient conditions

Temperature range	+5 ... +40 °C
Relative air humidity	10 ... 90 %, non-condensing

Device parameters

Dimensions (length x width x height)	180 mm x 130 mm x 50 mm
Mass	approx. 0.75 kg

1.7 Available accessories

The following accessories are available as standard products. Please ensure you note the time this instruction manual was issued, if necessary please ask the customer service department of Dr. Hielscher GmbH for any new additions to the accessories available:

Sonotrodes

Standard sonotrodes are used for the UP50H and UP100H ultrasonic processors, depending on their dimensions and acoustic power.

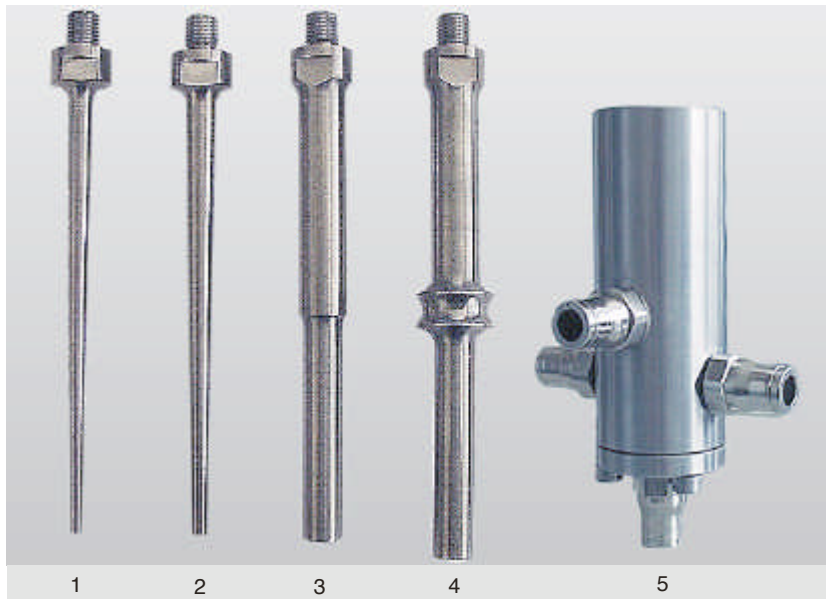

Key

- 1 Micro tip MS2
- 2 Micro tip MS3
- 3 Micro tip MS7
- 4 Flow tip MS7D
- 5 Flow vessel D7K (see Section "Further Components")

Figure 1-2 Selected standard sonotrodes and flow vessels

Table 1-1 shows the performance data of the standard sonotrodes for both ultrasonic processors.

Title	max. sub-merged depth (mm)	Tip diameter (mm)	max. amplitude (μm)	Acoustic power density (W/cm^2)
MS0,5 Micro tip 0.5	5	0.5	140	125
MS1 Micro tip 1	5	1	140	125
MS2 Micro tip 2	30	2	220	600
MS3 Micro tip 3	30	3	180	460
MS7 Micro tip 7	30	7	125	130
MS7D Flow tip 7	30	7	125	130
MS10 Micro tip 10 (only for UP100H)	30	10	70	90

Table 1-1 Standard sonotrodes

Dr. Hielscher GmbH also develops special sonotrode designs for special applications.

Further components

Stand clamp STH	Suitable for all stands with a pole diameter 16 mm
Sound control box SB2	Protective box for reducing sound, reduces the continuous sound pressure level by 20 dB The sound control box has an adjustable plate inside as a standing area for the acoustic irradiation container.
Stand ST1 with footplate	Stand made of stainless steel Footplate 300 mm x 150 mm, Pole diameter 16 mm
Timer T1	Electronic timer for controlling the duration of acoustic irradiation, 1 s to 99 min. Connection via the PC interface
Flow vessel D7	Usable with flow tip MS7D (see Table 1-1) stainless steel, autoclavable, without cooling.
Flow vessel D7K	Usable with flow tip MS7D (see Table 1-1) stainless steel, autoclavable, with cooling
PC connection and concomitant software:	
UPC	PC connection (own interface) for recording output (sonotrode amplitude, acoustic power) extent of delivery: PC plug-in printed circuit board, connection cable, and software
UPCT	PC connection (own interface) for recording output and temperature (sonotrode amplitude, acoustic power, temperature in liquid medium) Extent of delivery: PC plug-in printed circuit board, connection cable, sensor, and software.

2 Safety

2.1 Symbols used

Symbols in the manual



Symbolises an immediate threat of serious injury or even death due to hazard.



Warning of a possible hazardous situation, the consequences of which could be head injuries.



Warning of potential damage to property without risk to people.



Electric voltage!



Risk of explosion!



Hot surface! Do not touch!



Wear ear protection!

Symbols on the device



CE conformity mark

2.2 Use as prescribed

The UP50H and UP100H ultrasonic processors exclusively serve the acoustic irradiation of liquid media or solid media in a liquid bath (each with submerged sonotrode tip or from the air) for the

- Disintegration or homogenisation of liquids
- Thermoplastic deformation
- Protective coat removal
- Intensive cleaning of flat substrates
- FIA.

The ultrasonic processors may only be used so that the sonotrode tip withers stands a few millimetres above the liquid or submerged in the liquid according to the maximum submerged depth of the respective sonotrode type at the most.

Any other use than the one described here is outside the specification and can lead to hazardous conditions. Any use not described here is impermissible and not covered by the warranty and guarantee arrangements and obligations between Dr. Hielscher GmbH and other parties. Dr. Hielscher GmbH refuses to accept any responsibility for damage, losses and/or injuries or death, which result from use deviating from the information given in this instruction manual.

2.3 Safety information

General information

- Check your ultrasonic processor for damage before each use!
- Install the cable so that it cannot be stepped on or trip people up.
- Do not cover the ventilation slits in the housing. Do not allow any liquids to get into the housing!

Risk of burns

- Do not touch the horn and sonotrode during operation, you risk being burned! Leave the ultrasonic processor to cool after lengthy operation, before touching it. In case of continuous operation lasting several hours, the horn in particular can heat up to 100°C.

Hazards due to electric current

- Ensure that the supply voltage complies with the specifications, see the rating plate of the ultrasonic processor.
- Do not open the housing of the ultrasonic processor, risk of an electric shock!

- Do not carry any devices or parts by their cables!
- Protect all electric cables against heat, oil, solvents and sharp edges.

Hazards caused by sonic waves

- Never point the ultrasonic processor at people!
- When working for a lengthy period, wear suitable ear protection or run the ultrasonic processor in the sound control box SB2.
- Avoid running the ultrasonic processor in the presence of animals. Animals have an extended audible frequency range compared with humans.

Handling hazardous substances

- The owner/operator is responsible for defining the procedures for handling hazardous substances, including cleaning the sonotrodes and specification of the permissible cleaning agents (and separately according to working with hazardous or non-hazardous substances). The owner/operator of the ultrasonic system must make these procedures known in a suitable way and ensure compliance.

3 Structure and Function

3.1 Structure

The ultrasonic transducer is integrated in a housing, which has been ergonomically matched to the human hand. The sonotrode is coupled to the ultrasonic processor via the horn.

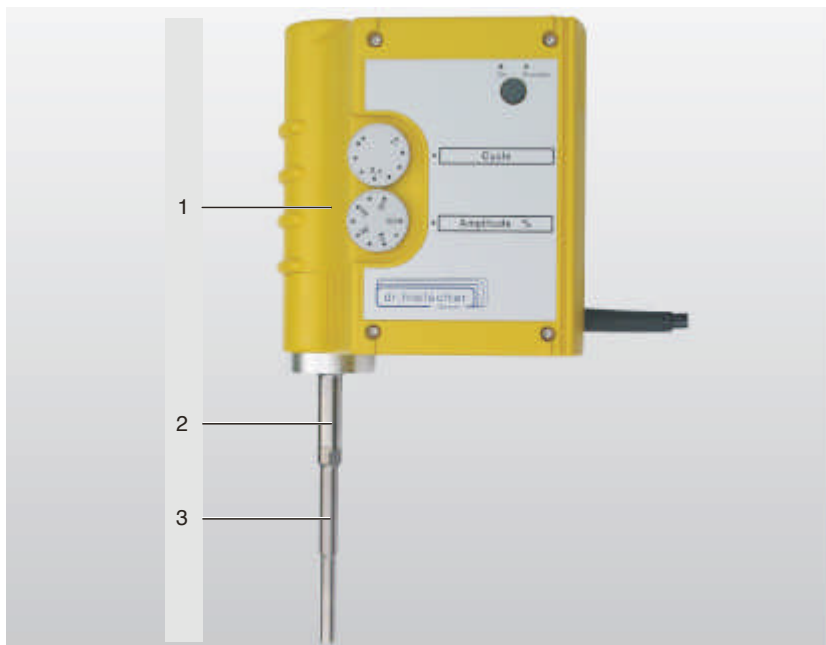

- Key**
- 1 Housing
 - 2 Horn
 - 3 Sonotrode

Figure 3-1 Structure of the ultrasonic processor

3.2 Functional principle

The ultrasonic processor generates longitudinal mechanical vibrations by means of electric excitation (reversed piezoelectric effect) with a frequency of 30 kHz. The power output of the processor can be steplessly adjusted between 20% and 100% of the maximum output (see Section 1.6 "Technical data").

The vibrations are amplified by the sonotrode fitted to the horn and formed as a $\lambda/2$ vibrator and transferred via its end face to the medium to be sonically irradiated. When using the UP50H and UP100H ultrasonic processor, the medium to be sonically irradiated is always a liquid.

The ultrasound causes cavitation in the liquid, which can be used for various purposes (see Section 1.3 "Areas of use"). Solid bodies are placed in a liquid for acoustic irradiation, here the liquid transfers the ultrasound to the surface of the material (e.g. for removing layers of paint). The transferred acoustic

power density depends on the form of sonotrode and the size of the sonotrode end face.

The various sonotrodes available provide an optimum selection for solving different tasks.

An integrated PC interface with special control enables the PC aided monitoring and control of all the important parameters of the ultrasonic processor and the connection of additional sets (e.g. temperature probes).

3.3 Operating and display elements

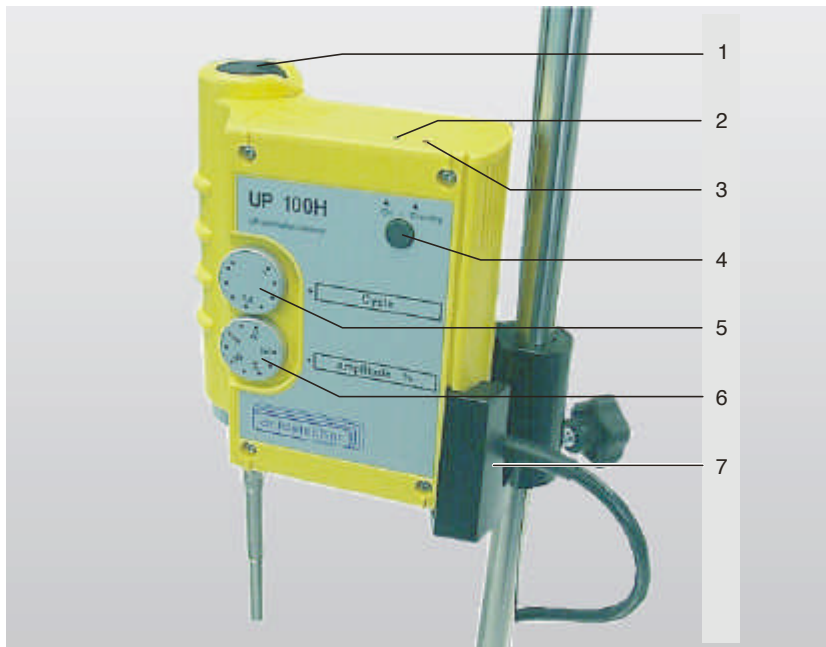

Key

- 1 Start key
- 2 Red LED: Ready for service
- 3 Green LED: trouble-free operation
- 4 Locking key for continuous operation
- 5 Rotary regulator for pulse control mode (control of the clock pulse ratio)
- 6 rotary regulator for amplitude (ultraacoustic power output)
- 7 Stand clamp (concealed behind it: PC interface)

Figure 3-2 Operating and display elements of the ultrasonic processor

The individual elements have the following functions:

Red LED readiness for service

Lights up, if the mains voltage is applied to the ultrasonic processor (stand-by).

Green LED Operation

When the ultrasonic processor is switched on, indicates problem-free operation.

Start key

Switch the ultrasonic processor on/off.

- Keep depressed for the duration of the acoustic irradiation.
- Release to switch off.

Locking key for continuous operation

Switch over the already switched on ultrasonic processor to continuous operation.

- Switch on continuous operation: Press the start key and keep depressed, briefly press the locking key briefly.
- Switch off: press the start key again.

Rotary regulator for pulse control mode (Cycle)

Adjust the pulse mode factor for pulse control mode (Switch On-/off times for the ultrasonic processor).

Examples for settings:

Setting	Significance
1	Continuously switched on
0,6	Power discharge 0.6 seconds, pause 0.4 seconds

Rotary regulator for the amplitude (ultrasonic output)

Control the amplitude/ultrasonic setting of the fitted sonotrode. The setting can be steplessly adjusted between 20% and 100%.

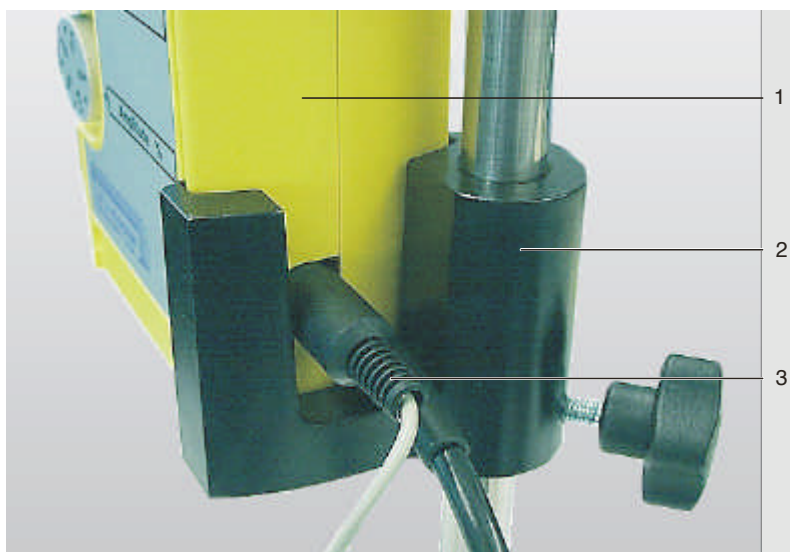

Key

- 1 Ultrasonic processor
- 2 Stand clamp
- 3 PC or timer cable at the PC interface

Figure 3-3 PC-interface

PC-interface

Special interface for connecting a PC or other components (timer); suitable PC plug-in printed circuit board and software are required. Plug-in printed circuit board and software are available from Dr. Hielscher GmbH.

3.4 Electrical connection

The ultrasonic processor is electrically connected to the appropriate socket via a earthing pin plug. The connection values are country-specific, see the rating plate on the ultrasonic processor housing.

Please note:

Connection values

*Note the specific connection values for the electric connection of the ultrasonic processor!
See rating plate on the device.*



3.5 Sonotrodes

Always select the sonotrode according to the following criteria:

- The task to be solved
- The volume to be acoustically irradiated
- The penetration depth required.

Sonotrodes are differentiated according to the acoustic power or acoustic power density they transfer.

Note:

The smaller the end face area A of the sonotrode, the lower the acoustic power P introduced ($P_{\text{sonic}} \sim A_{\text{end face}}$).

The amplitude s and acoustic power density N on the other hand increase as the end face area reduces and the cavitation intensity at the sonotrode tip increases ($s, N_{\text{sonic}} \sim 1/A_{\text{end face}}$).

Please use any information sheets provided as part of the extent of delivery to inform yourself about special properties, possible uses and installation of the sonotrodes supplied.

4 Commissioning

4.1 Room requirements

The ultrasonic processor is designed for normal laboratory rooms or workshops with conditions similar to those in laboratories.

Use in potentially explosive environments

Do not use the ultrasonic processor in potentially explosive areas! There is a risk of an explosion and thus a high risk of injury!



4.2 Install and dismantle the sonotrode

Prerequisites

To install or dismantle a sonotrode you will require:

- face spanner size 3
- open jawed spanner SW 9

Both tools are part of the extent of delivery.

Soiled or damaged contact areas

The contact areas of the sonotrode and horn must be clean, free of grease, dry and undamaged. Screw the sonotrode very tightly onto the horn of the ultrasonic processor.



Otherwise the power transmission from the ultrasonic processor to the sonotrode will be disrupted and the processor automatically changes to pulse control mode.

Install sonotrode

The sonotrode must be very firmly connected with the horn of the ultrasonic processor. Install the sonotrode to the ultrasonic processor as follows:

1. Turn the sonotrode hand-tight in the tapped hole of the horn.
2. Spread out the face spanner and place against two opposite drill holes in the horn.

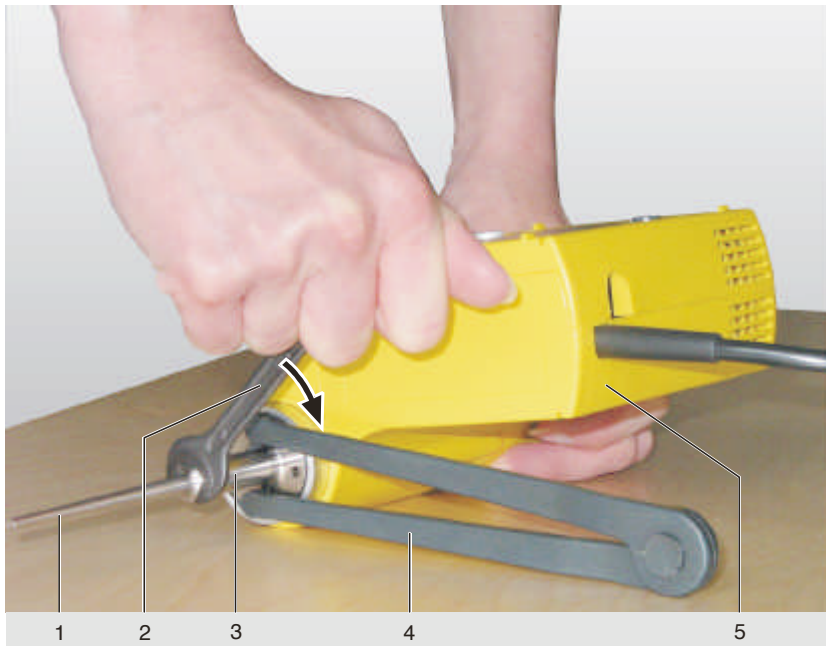

Key

- 1 Sonotrode
- 2 Open jawed spanner
- 3 Horn
- 4 Face spanner
- 5 Ultrasonic processor

Figure 4-1 Install sonotrode

3. Place the ultrasonic processor on a firm base (table) (Figure 4-1), so that the face spanner also sits on the base and serves as a support.
4. Set the open jawed spanner on the key surfaces of the sonotrode.
5. Press down the open jawed spanner in the direction of the base and thus tighten the sonotrode (approx. 30 Nm).

Dismantle sonotrode

The sonotrode is dismantled in the reverse order and direction.

1. Place the ultrasonic processor on the base so that the firm base forms the support for the face spanner, while you press down the open jawed spanner (Figure 4-2).

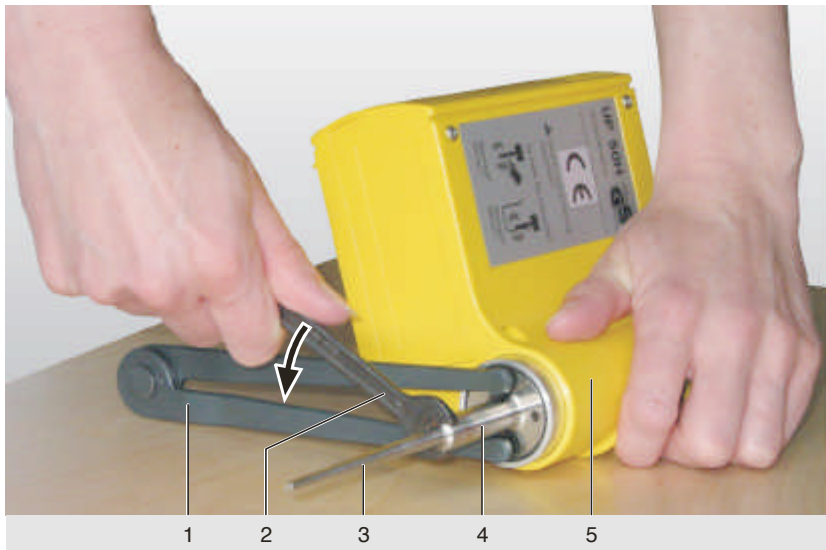

Key

- 1 Face spanner
- 2 Open jawed spanner
- 3 Sonotrode
- 4 Horn
- 5 Ultrasonic processor

Figure 4-2 Dismantle the sonotrode

2. Loosen the sonotrode
3. Completely unscrew the sonotrode from the horn by hand.

4.3 Stand assembly

To fit the ultrasonic processor on a stand you will require the stand clamp STH (see Section 1.7 “Available accessories“). This clamp fits each stand with a pole diameter of ½ inch. The pole should be at least 300 mm long.

How to fit the ultrasonic processor onto the stand:

1. Fix the stand clamp at the required height on the stand pole
2. Set the ultrasonic processor with fitted sonotrode in the stand clamp (Figure 4-3)
3. Loosen the stand clamp and slide the ultrasonic processor towards the acoustic irradiation vessel at the optimum working height for the fitted sonotrode.

Note the maximum submerged depth

The sonotrode must not be submerged by more than its maximum submerged depth in the medium to be acoustically irradiated.!

Maximum submerged depth of the sonotrode: See Table 1-1.



The submerged depth of the sonotrode can vary depending on the task. All depths less than the maximum submerged depth

are possible, including acoustic irradiation above the surface of the liquid for example to atomise liquids or to enrich the sample with air.

The maximum submerged depth of the sonotrode is given in Table 1-1.

4. Screw the stand clamp tight.

You can remove the ultrasonic processor from the fitted stand clamp at any time and reproducibly attach it to the same working position.

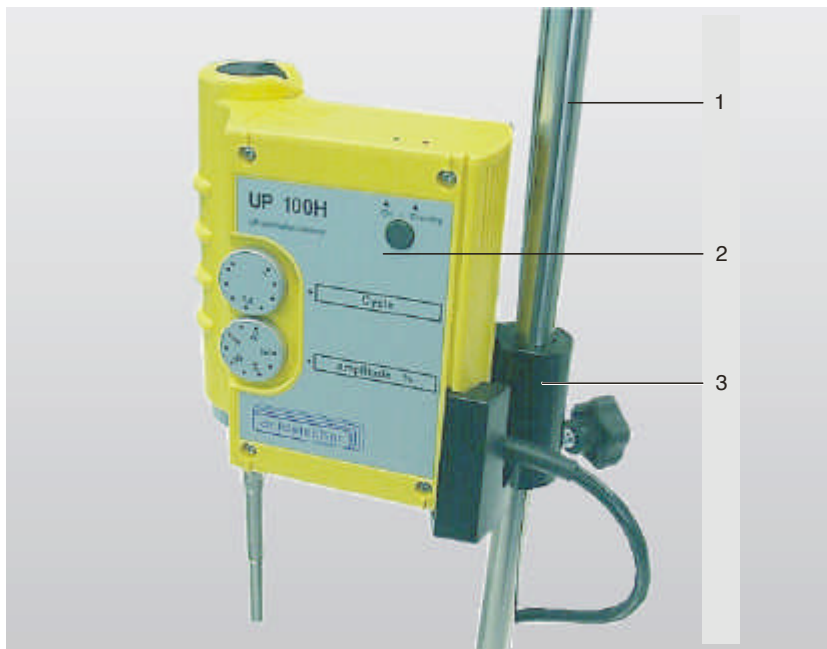

- Key**
- 1 Stand
 - 2 Ultrasonic processor
 - 3 Stand clamp

Figure 4-3 Ultrasonic processor on the stand

4.4 Electric connection

Note the electric connected loads!

Ensure that the electric connection matches the required connection data of the ultrasonic processor!

For the connection data, see the rating plate on the equipment housing or Section 1.6 "Technical data" of this instruction manual.



The electric connected loads for your device are given on the rating plate on the ultrasonic processor housing.



Figure 4-4 Rating plate of an ultrasonic processor UP50H (electric connected loads are country-typical)

1. Insert the mains plug of the ultrasonic processor in a socket outlet with earthing contact.

The red LED readiness for service lights up and thus indicates the readiness for service (stand-by-mode) of the ultrasonic processor.

4.5 PC or timer connection

The ultrasonic processor has a special interface (Figure 3-3) for the connection of a PC or other components (e.g. timer, see Section 1.7 “Available accessories”).

5 Operation

Depending on the planned acoustic irradiation time for the sample, select manual mode (see Section 5.1 “Manual mode – the correct”) or stand assembly (see Section **Fehler! Verweisquelle konnte nicht gefunden werden.** “Stand assembly”) of the ultrasonic processor.

5.1 Manual mode – the correct hold

The housing of the ultrasonic processor, especially the handle, is ergonomically matched to the human hand. The shaped thumb channel to the start key provides additional lateral grip.

Hold the ultrasonic processor in your right hand as shown in Figure 5-1. In this way, you always have all the operating elements in view.



- Key**
- 1 Start key
 - 2 Sonotrode
 - 3 Acoustic irradiation vessel

Figure 5-1 Ultrasonic processor in manual mode

5.2 Switch the ultrasonic processor on and off

Before switching on the ultrasonic processor, prepare your sample(s).

Switching on with the minimum power

Always switch on the ultrasonic processor at the lowest power setting. Do not adjust the working parameters for the acoustic irradiation (amplitude, pulse mode factor) to a higher value until the device is running.

In this way, you avoid accidental foaming or splashing of the sample liquid.



Prerequisites for switching on

- The samples to be acoustically irradiated have been prepared
- The ultrasonic processor is electrically connected (mains plug in the socket)
- The red LED “readiness for service” is lit up.

Switching on and off

When running the ultrasonic processor, please note the following:

Risk of injury due to glass splinters

Do not touch glass acoustic irradiation vessels with the vibrating sonotrode!

Pressure and cavitation can cause the glass to splinter and lead to injuries!



Risk of explosion

Only acoustically irradiate easily flammable samples with adequate ventilation under a switched on extraction hood!

Otherwise there is a risk of explosion!



Risk of burns from hot sonotrode

Do not touch the sonotrode and horn during operation! The sonotrode and horn can heat up to 100°C.

There is a risk of injury due to the hot surfaces!



Wear ear protection!

When working with the ultrasonic processor for lengthy periods, you should always wear suitable ear protection!



Otherwise lasting damaged hearing can be the consequence.

1. Set the amplitude at the rotary regulator to 20% (minimum) (see Figure 3-2)

This way you avoid accidental foaming or splashing of the sample.

2. Submerge the sonotrode in the medium to be acoustically irradiated

Ensure that the maximum submerged depth for your sonotrode is not exceeded (see Table 1-1).

3. Press the start key on the ultrasonic processor for as long as the medium is to be exposed to the sonic waves.

The green LED lights up if the ultrasonic processor is working problem free.

4. Vary the working parameters according to Section 5.3 "Vary working parameters".

5. Release the start key, if you want to switch off the ultrasonic processor.

Switch during continuous operation

6. Simultaneously press the start key for and the electronic locking key at the ultrasonic processor for a short time (see Figure 3-2).

To switch the ultrasonic processor back off, press the start key again.

5.3 Vary the working parameters

Vary the amplitude / ultrasonic output

1. The oscillation amplitude (and thus the ultrasonic output) is controlled at the rotary regulator for amplitudes between 20% and 100% (see Section 3.3 "Operating and display elements", Figure 3-2).

The maximum oscillation amplitude (100%) of a sonotrode depends on its design. Please refer to this value for your sonotrode in Table 1-1 in Section 1.7 "Available accessories".

Adjust pulse control mode

2. Adjust the pulse mode in pulse control mode using the rotary regulator cycle (Figure 3-2).

For permanent acoustic irradiation, turn the controller to “1”; each other setting means shorter sonic radiation times with corresponding breaks (see Section 3.3 “Operation and display elements”).

6 Help With Faults

The UP50H and UP100H ultrasonic processors are internally secured against the usual operational overload situations. Should problems nevertheless occur, the following overview can help you to find a solution.

6.1 Faults

Case A The ultrasonic processor automatically switches into pulse control mode.

Question Is the sonotrode securely screwed onto the ultrasonic processor?

Solution Undo the connection and reinstate. The sonotrode must sit very firmly on the ultrasonic processor. See Section 4.2 "Install and dismantle the sonotrode".

Question Are the contact surfaces between the ultrasonic processor and the sonotrode really clean, grease free and undamaged?

Solution Undo the connection, check the contact areas and clean if necessary, then reinstate the connection. If a surface is damaged, please call our service department (see Section 6.2 "Service address and telephone number").

Question Is the sonotrode tip worn by cavitation?

Solution Replace the worn sonotrode, because excessive material wear can no longer be compensated for by the control electronics. Contact our service telephone – we will quickly supply a replacement sonotrode.

Case B The ultrasonic processor cannot be switched on, although the plug is in the mains.

Question Is the mains voltage the same as the specification?

Solution Check the mains voltage, ensure that the connected load against the information on the rating plate of the ultrasonic processor or against the values given in Section 1.6 "Technical data" of this instruction manual.

Question Has liquid penetrated the housing?

Solution Send the ultrasonic processor to our customer service department with as detailed a description as possible of the faults. Please call our service department first.

Question You still can't switch the device on?

Solution Call our service department. Our service telephone number and address are given in Section 6.2 "Service address and telephone number".

6.2 Service address and telephone number

Our service telephone team will be pleased to help you in case of complications:

Dr. Hielscher GmbH

Warthestraße 21

D-14513 Teltow

Telephone +49 (0) 33 28 / 437 3

Fax +49 (0) 33 28 / 437 444

7 Servicing and Maintenance

The UP50H and UP100H ultrasonic processors are maintenance free, the sonotrodes are wearing parts.

Cleaning

Clean the ultrasonic processor and the sonotrode as needed using a damp cloth. You can add a mild washing up agent to the water.

Depending on the media in which it is used, the sonotrode can also be cleaned using a cloth moistened with alcohol.

Ensure that no water or other liquid gets into the ultrasonic processor housing!

Replace worn parts

Change the sonotrodes if they are worn due to cavitation. Worn sonotrodes have a rough, damaged surface.

8 Decommissioning and Transport

To decommission the ultrasonic processor:

1. Switch off
2. Remove the mains plug
3. Remove from stand if applicable
4. Dismantle sonotrode

Pack the parts of your ultrasonic processor safely for transport and storage, if possible in their original packaging. Store the device in a dry room.

9 Disposal

If delivered to us with prepaid transport costs, Dr. Hielscher GmbH takes back old devices free of charge. We dispose of them in an environmentally compatible way or recycle the parts.

Please contact our service department before you send your device to us.

Materials used:

- Electric and electronic components
- Ceramics
- Titanium alloys for the sonotrodes

Declaration of Conformity

in accordance with FunkStörG, EMVG 1. GSGV

Dr. Hielscher GmbH
Warthestraße 21
D-14513 Teltow

We herewith declare that the design and type of device described in the following and the version sold on the market by us den complies with the fundamental health and safety requirements of the EU Directives named in the following, which have all been adopted under German law.

This declaration becomes invalid if the device is modified without our consent.

Type of device Ultrasonic processor for manual and stand operation

Types UP50H
 UP100H

Applicable EU Directives 89/336/EWG (Electromagnetic compatibility), amended by 93/31/EEC
 73/23/EEC (Low Voltage Directive)

Harmonised standards used EN 55011 (Radio noise)
 EN 61000-6-1 (Noise immunity)
 Only for UP100H:
 EN 61000-3-2 (Harmonic components)
 EN 61000-3-3 (Voltage fluctuations)

German standards used VDE 0875 Part 11 (Limiting value Class B)
 contained in EN 55011

Date 23rd September 2002

Signature 

Managing Director